

# installation manual



**Congratulations, you have purchased the finest propeller shaft seal available, and we are here to help you install it correctly.** Please read through **ALL instructions** thoroughly before installing the Lasdrop Seal. If you are unfamiliar with any part of the process, we recommend a skilled licensed marine mechanic perform the installation.



**DESIGNED & ENGINEERED IN THE USA**

## seal diagram

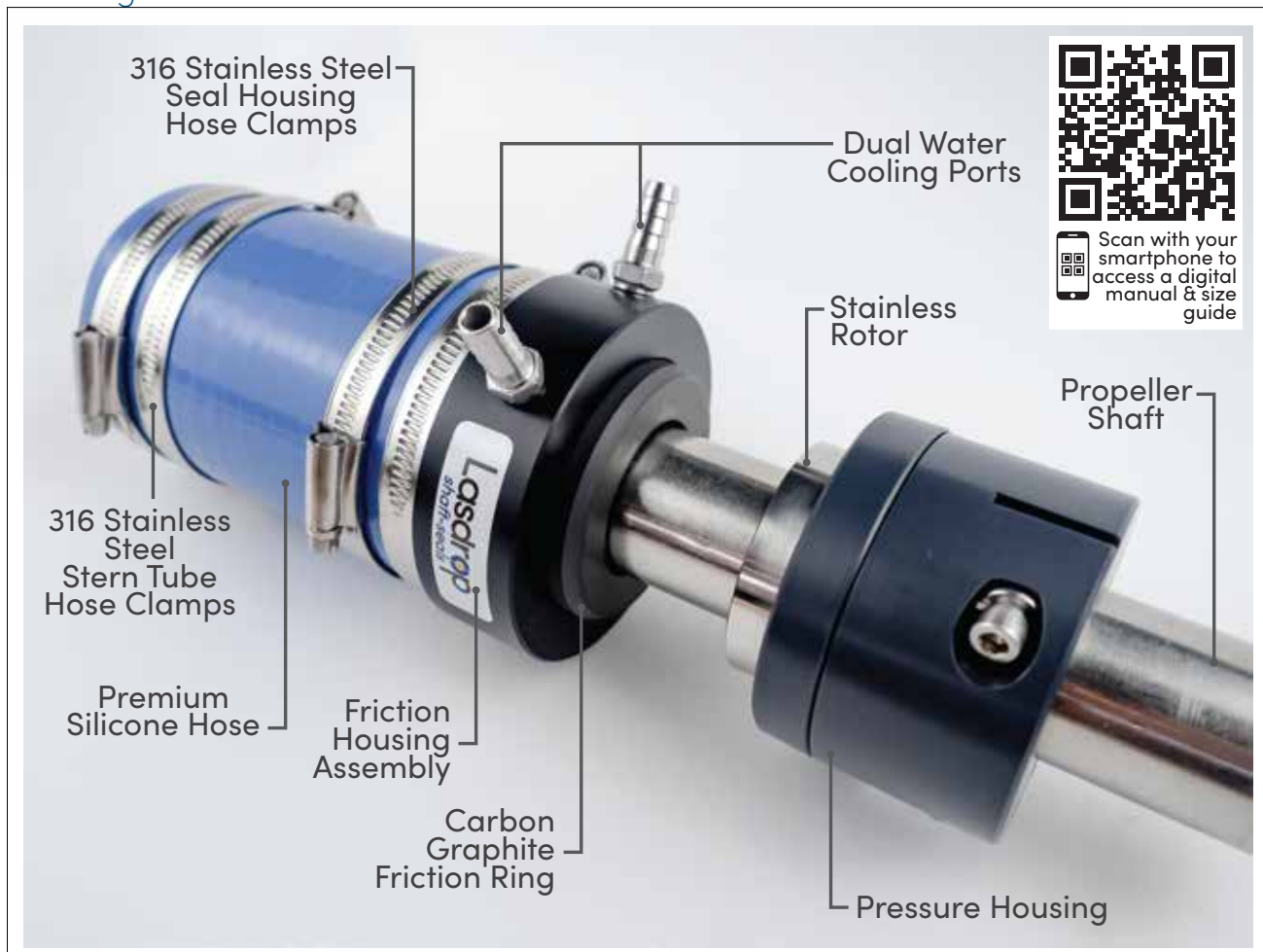

## STEP-BY-STEP INSTRUCTIONS



You are about to install the Lasdrop Generation 2 propeller shaft seal. The Gen 2 is a mechanical face seal. The benefit of this technology allows for no wear on a vessel's running gear and insures minimal maintenance for extended periods of time.

- 1 Before removing your existing shaft seal(s), or stuffing box slide old seal(s) forward and **be sure the shaft is center to the stern tube/shaft log**. Proper shaft alignment will greatly increase the life of your new Lasdrop seal.
- 2 Clean the shaft as thoroughly as possible with very fine sandpaper (400 to 600 grit). Remove any sharp edges or burrs from shaft and keyway.

### FRICITION ASSEMBLY INSTALLATION

- 3 Slide the **Friction Housing Assembly** over the shaft and connect it to your stern tube with supplied 316 stainless hose clamps. (Note: position the assembly with water injection ports facing up).

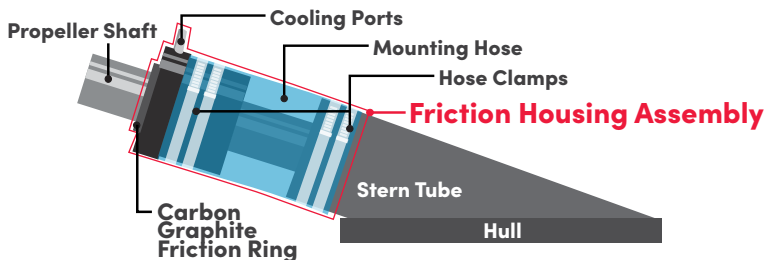

### FRICITION ASSEMBLY INSTALLATION INSIGHTS

† If the shaft is not centralized with the stern tube, or if any misalignment is found - be sure the shaft is center to the stern/shaft tube before continuing installation. If you are unfamiliar with any part of the process, we recommend a skilled licensed marine mechanic perform the installation.

## PRESSURE HOUSING INSTALLATION

- 4 Use the supplied installation starter plug to install the Pressure Housing assembly over the shaft. Verify that there are two (2) rod seals that are installed inside the bore of the stainless rotor and lubricate with liquid soap.

**IMPORTANT** - Use liquid soap to lubricate the inner rod seals and shaft.

**CAUTION:** do not use oil, grease, or silicone as a lubricant.

On the stainless end of the pressure housing press the installation plug (tapered portion first) into to the first rod seal inside the assembly so that it is wedged.

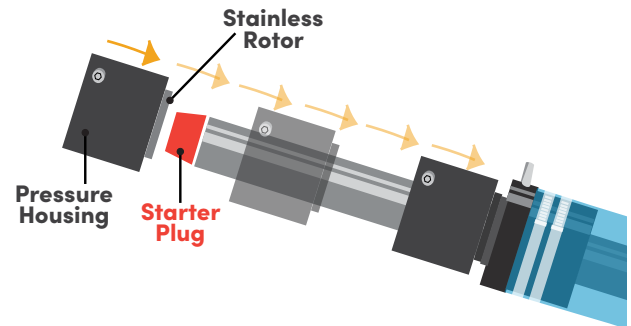

- 5 Carefully push the Pressure Housing assembly onto the shaft allowing the starter plug to travel through the assembly. This allows the rod seals to spread open and prevents them from rolling out of place (save starter plug for future maintenance).
- 6 Reassemble shaft and coupling then bolt to transmission or V-Drive.

### SEAL FACE PRESSUE ADJUSTMENT

- 7 Slide the Pressure Housing down the shaft until it just touches the carbon face on the Friction Housing Assembly. Mark this position on the shaft as the neutral position with a permanent marker or electrical tape.

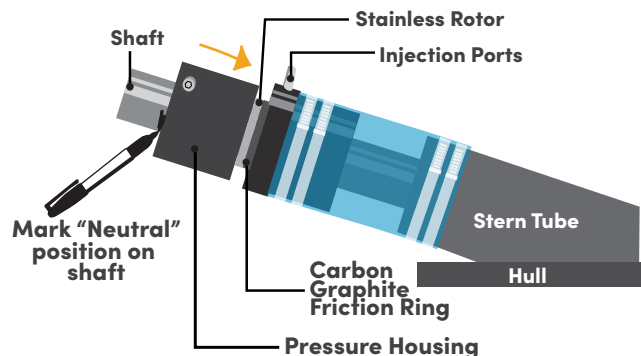

- 8 Sliding the pressure housing aft, compress the stainless rotor one quarter inch (1/4" - 7mm) and snug the socket head cap screws on the fore end of the assembly (approximately 3-foot pounds (4 Nm) of torque).

**CAUTION** – do not over tighten.

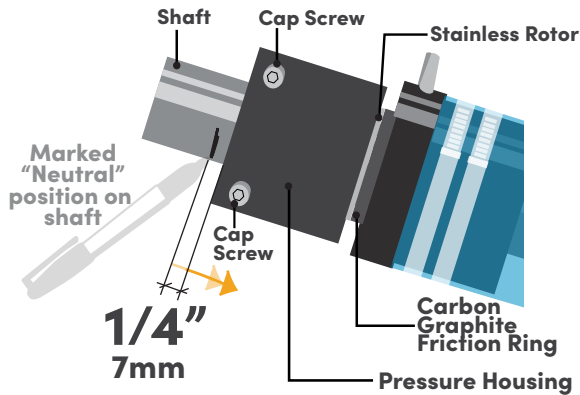

- 9 Your seal is now secured to your shaft - see "Water Supply Installation" to complete the installation process.

## WATER SUPPLY LINE INSTALLATION



The Gen2 Seal™ requires water for cooling and lubrication.



**Water supply line kit sold separately**  
(water supply line and accessories not included with standard shaft seal kit - separate purchase required contact Lasdrop or any authorized Lasdrop Distributor to order your premium kit)

### Hulls BELOW 10 Knots (displacement hull)



At low speeds, the water supply line can be installed as a "Vent Line" that allows air to escape from the seal instead of water injection. At these speeds, the stern tube is typically flooded, thus providing plenty of lubrication.

**WARNING!** If engine is below the waterline, a loop or air trap in the supply line should be used. Route the "vent line" above the waterline.

### Hulls ABOVE 10 Knots (planing hull)



High speed hulls MUST inject water into the seal. Supply water can come from a clean source after the raw water pickup. Avoid supply water from exhaust manifolds and engine/manifold drain plugs due to potential debris.

**NOTICE:** All Lasdrop Shaft Seals above 1 inch come with two water injection ports. This is intended to provide water from both engines in the event supply is lost from one side or an engine is down. For single engine applications, a plug is included in the parts bag to replace one hose barb. Do not overtighten.

- 11 Your Gen2 Shaft Seal by Lasdrop Shaft Seals is now installed.

## GENERAL INSTALLATION TIPS

- When any service is performed, it is recommended the vessel be out of the water.
- When handling the Gen 2 seal assemblies, be cautious not to scratch or chip the carbon and stainless seal surfaces. This will cause an interruption in the hydroplaning that creates the mechanical face seal.
- When the vessel is out of the water for any period, it is recommended the seal is washed down with fresh water. This will eliminate salt crystals from forming on the seal surfaces.
- 1 hour break-in time is recommended for a newly installed Gen2 Seal.

**NOTICE:** If the vessel is not used on a regular basis, it is important to rotate the shaft(s) every two weeks. This will prevent oxygen deprivation from occurring between the seal surfaces which can cause pitting corrosion.

**Gen 2** Shaft Seal  
Lasdrop shaft-seals

DESIGNED & ENGINEERED  
IN THE USA

**Lasdrop.com**  
**800-940-SEAL**

(231) 794-5070 • info@lasdrop.com  
50 Greenbush St. | Manistee, MI 49660

**Lasdrop**  
shaft-seals  
a division of  
Navalcraft Specialties, Inc.

Phone: (231) 794.5070 | Toll Free: (800) 940.7325 | www.Lasdrop.com